

INFORMATION SHOWN HEREON DOES NOT CONSTITUTE, NOR DOES IT REPRESENT, A SURVEY OF THE SUBJECT PREMISES.

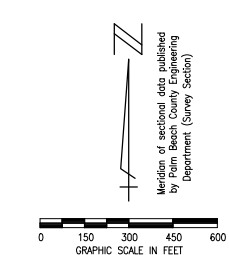

No.	TYPE	RECORDING DATA	INST. DATE	RECORDING DATE	REMARKS
E 1	IEE	PB 99/47-62	N/A	06/26/03	TRACT R-1
E 2		PB 99/47-62	N/A	06/26/03	OPEN SPACE 8
E 3		PB 99/47-62	N/A	06/26/03	OPEN SPACE 9
E 4		PB 99/47-62	N/A	06/26/03	LAKE TRACT 7
E 5		PB 99/47-62	N/A	06/26/03	LAKE TRACT 8
E 6		PB 99/47-62	N/A	06/26/03	OPEN SPACE 21
E 7		PB 99/47-62	N/A	06/26/03	WETLAND 4
E 8		PB 99/47-62	N/A	06/26/03	UPLAND 11
E 9		PB 99/47-62	N/A	06/26/03	UPLAND 10
E 10		PB 99/47-62	N/A	06/26/03	WETLAND 3
E 11		PB 99/47-62	N/A	06/26/03	UPLAND 9
E 12		PB 99/47-62	N/A	06/26/03	LAKE TRACT 3
E 13		PB 99/47-62	N/A	06/26/03	OPEN SPACE 22
E 14		PB 99/47-62	N/A	06/26/03	UPLAND 6
E 15		PB 99/47-62	N/A	06/26/03	LAKE TRACT 2
E 16		PB 99/47-62	N/A	06/26/03	WETLAND 1
E 17		PB 99/47-62	N/A	06/26/03	UPLAND 2
E 18		PB 99/47-62	N/A	06/26/03	OPEN SPACE 19
E 19		PB 99/47-62	N/A	06/26/03	UPLAND 4
E 20		PB 99/47-62	N/A	06/26/03	UPLAND 5
E 21		PB 99/47-62	N/A	06/26/03	UPLAND 3
E 22		PB 99/47-62	N/A	06/26/03	WETLAND 2
E 23		PB 99/47-62	N/A	06/26/03	UPLAND 8
E 24		PB 99/47-62	N/A	06/26/03	UPLAND 7
E 25		PB 99/47-62	N/A	06/26/03	LAKE TRACT 4
E 26		PB 99/47-62	N/A	06/26/03	OPEN SPACE 10
E 27		PB 99/47-62	N/A	06/26/03	LAKE TRACT 5
E 28		PB 99/47-62	N/A	06/26/03	OPEN SPACE 11
E 29		PB 99/47-62	N/A	06/26/03	UPLAND 1
E 30		PB 99/47-62	N/A	06/26/03	LAKE TRACT 6

LEGEND:

WME	denotes Water Management Easement	IP-1	denotes Irrigation Pump
WMME	denotes Water Management Maintenance	E-1	denotes District Easement
IEE	denotes Ingress-Egress Easement	T-1	denotes District Owned Tract
GCAE	denotes Golf Course Access Easement	F-1	denotes Flashboard Riser
WMAE	denotes Water Management Access Easement	W-1	denotes Weir
E	denotes Utility Easement	PS-1	denotes Pump Station
DE	denotes Drainage Easement	C-1	denotes Culvert
CE	denotes Conservation Easement	TE-1	denotes Telemetry Catwalk with Metropate
PE	denotes Preservation Easement	OS-2	denotes Operable Gate Structure
PT	denotes Wetland Preservation Tract	(RW-1)	denotes Recharge Well
WPA	denotes Wetland Preservation Area WMT	(MW-1)	denotes Hazardous Material Monitoring Well
MT	denotes Water Management Tract	(WQ-1)	denotes Water Quality Sampling Station
LOA	denotes Land Owners Agreement	SG-1	denotes Staff Gauge
NPBCID	denotes Northern Palm Beach County Improvement District	RG-1	denotes Rainfall Gauge
NCVD	denotes National Geodetic Vertical Datum	—>	denotes Flow direction
IE	denotes Invert Elevation (NGVD)		
OMP	denotes Corrugated Metal Pipe		
RCP	denotes Reinforced Concrete Pipe		
(Symbol: 22 23 24 25 26)	denotes Recorded Plat Corner		
(Symbol: 22 23 24 25 26)	denotes Palm Beach County Section Corner		
(Symbol: 22 23 24 25 26)	denotes Palm Beach County Section Quarter Corner		
—	denotes NPBCID Unit Boundary		
- - -	denotes NPBCID Fee Simple Tract		
- - -	denotes NPBCID Easements		
- - -	denotes Palm Beach County Section Lines		

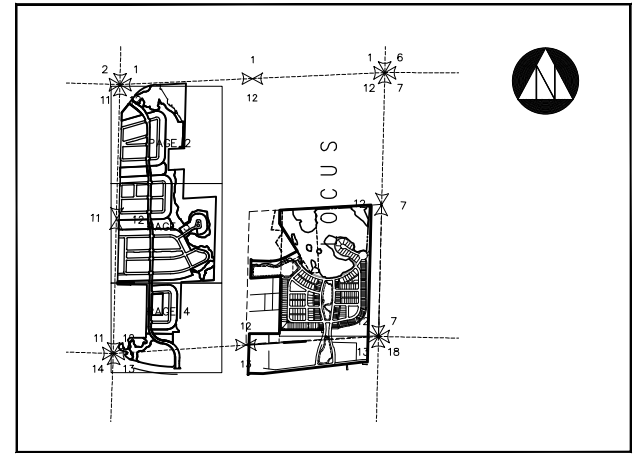

No.	RECORDING DATA	INST. DATE	RECORDING DATE	OWNED TRACTS	REMARKS
T 1	PB 99/47-62	N/A	06/26/03	TRACT R-2	
T 2	PB 99/47-62	N/A	06/26/03	TRACT R-3	
T 3	PB 99/47-62	N/A	06/26/03	TRACT R-4	
T 4	PB 99/47-62	N/A	06/26/03	TRACT R-5	
T 5	PB 99/47-62	N/A	06/26/03	TRACT R-6	
T 6	PB 99/47-62	N/A	06/26/03	TRACT R-7	
T 7	PB 99/47-62	N/A	06/26/03	TRACT R-8	

No.	RECORDING DATA	INST. DATE	RECORDING DATE	NPBCID FACILITIES	REMARKS

No.	PLAT BOOK/PAGES	TITLE
1	PB 99/ 47-62	PIPES ON PENNOCK LANE P.L.D. PLAT NO. 2 (PASEOS)
2	PB 96/184-185	PIPES ON PENNOCK LANE P.L.D. PLAT NO. 1

LOT NUMBER	BLANKET EASEMENT RELEASE RECORDING DATA

No.	DATE	BY	REVISION
5	11-20-13	JMF	REVISE BORDER
4	02-20-08	MSB	NPBCID FACILITIES UPDATE
3	02-17-06	JCD	NPBCID FACILITIES UPDATE
2	SEPT 04	CAR	DENOTED PIPES OF PENNOCK LANE PLAT 1
1	MAR 04	J.D	ADDED EASEMENTS AND TRACTS FOR PLAT 2

FIELD: N/A
DRAWN: SFRN STAFF
DESIGNED: N/A
APPROVED: C.A.R.
SCALE: NOTED



NORTHERN PALM BEACH IMPROVEMENT DISTRICT
FACILITY MAP OF:
UNIT OF DEVELOPEMENT NO. 45
SECTIONS 12, 13 AND 14,
TOWNSHIP 41 SOUTH, RANGE 42 EAST,
PALM BEACH COUNTY, FLORIDA

SHEET 1 OF 4
DATE: 06-15-06
EXHIBIT 45 (1)

Date/Time : Wed, 13 Nov 2013 11:50:11 AM
 Path Name : C:\Projects\149\149_WF\059000\CAO\Unit-45\Facilities_Map\unit45r01.dwg

INFORMATION SHOWN HEREON DOES NOT CONSTITUTE, NOR DOES IT REPRESENT, A SURVEY OF THE SUBJECT PREMISES.



No.	TYPE	RECORDING DATA	INST. DATE	RECORDING DATE	REMARKS
E 1	IEE	PB 99/47-62	N/A	06/26/03	TRACT R-1
E 2		PB 99/47-62	N/A	06/26/03	OPEN SPACE 8
E 3		PB 99/47-62	N/A	06/26/03	OPEN SPACE 9
E 4		PB 99/47-62	N/A	06/26/03	LAKE TRACT 7
E 5		PB 99/47-62	N/A	06/26/03	LAKE TRACT 8
E 6		PB 99/47-62	N/A	06/26/03	OPEN SPACE 21
E 7		PB 99/47-62	N/A	06/26/03	WETLAND 4
E 8		PB 99/47-62	N/A	06/26/03	LIFELAND 11
E 9		PB 99/47-62	N/A	06/26/03	LIFELAND 10
E 10		PB 99/47-62	N/A	06/26/03	WETLAND 3
E 30		PB 99/47-62	N/A	06/26/03	LAKE TRACT 6

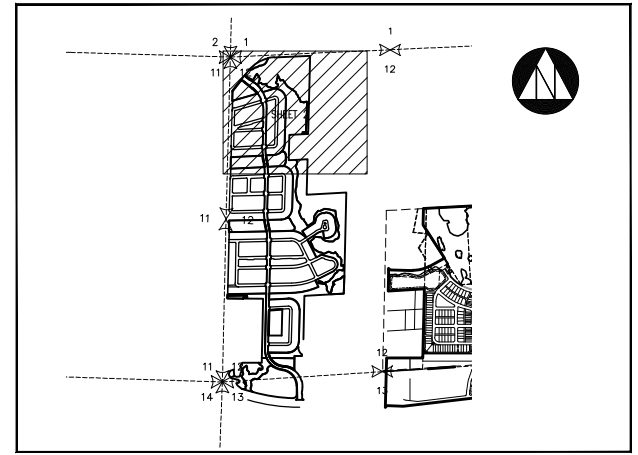

No.	RECORDING DATA	INST. DATE	RECORDING DATE	REMARKS
T 6	PB 99/47-62	N/A	06/26/03	TRACT R-7
T 7	PB 99/47-62	N/A	06/26/03	TRACT R-8

No.	REMARKS

No.	PLAT BOOK/PAGES	TITLE
1	PB 99/47-62	PINES ON PENNOCK LANE P.U.D. PLAT NO. 2 (PASEOS)

LOT NUMBER	BLANKET EASEMENT RELEASE RECORDING DATA

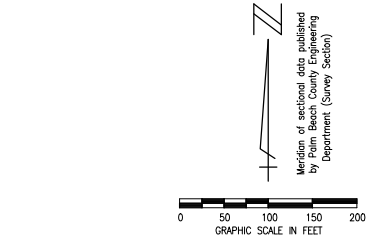

- LEGEND:**
- | | | | |
|--------|---|------|--|
| WME | denotes Water Management Easement | IP-1 | denotes Irrigation Pump |
| WMME | denotes Water Management Maintenance | E-1 | denotes District Easement |
| IEE | denotes Ingress-Egress Easement | T-1 | denotes District Owned Tract |
| GCAE | denotes Golf Course Access Easement | F-1 | denotes Fishboard Riser |
| WMAE | denotes Water Management Access Easement | W-1 | denotes Weir |
| E | denotes Utility Easement | PS-1 | denotes Pump Station |
| DE | denotes Drainage Easement | C-1 | denotes Culvert |
| CE | denotes Conservation Easement | TE-1 | denotes Telemetry Catwalk with Metritape |
| PE | denotes Preservation Easement | OS-2 | denotes Operable Gate Structure |
| PT | denotes Wetland Preservation Tract | RW-1 | denotes Recharge Well |
| WPA | denotes Wetland Preservation Area WMT | MW-1 | denotes Hazardous Material Monitoring Well |
| MT | denotes Water Management Tract | WQ-1 | denotes Water Quality Sampling Station |
| LOA | denotes Land Owners Agreement | SG-1 | denotes Staff Gauge |
| NPBCID | denotes Northern Palm Beach County Improvement District | RG-1 | denotes Rainfall Gauge |
| NGVD | denotes National Geodetic Vertical Datum | — | denotes Flow direction |
| IE | denotes Invert Elevation (NGVD) | | |
| CMP | denotes Corrugated Metal Pipe | | |
| RCP | denotes Reinforced Concrete Pipe | | |
| | denotes Recorded Plat Corner | | |
| | denotes Palm Beach County Section Corner | | |
| | denotes Palm Beach County Section Quarter Corner | | |
| | denotes NPBCID Unit Boundary | | |
| | denotes NPBCID Fee Simple Tract | | |
| | denotes NPBCID Easements | | |
| | denotes Palm Beach County Section Lines | | |

No.	DATE	BY	REVISION
5	11-20-13	JAF	REVISE BORDER
4	02-20-06	MCB	NPBCID FACILITIES UPDATE
3	02-17-05	JCD	NPBCID FACILITIES UPDATE
1	MAR 04	JD	ADDED EASEMENTS AND TRACTS FOR PLAT 2

FIELD: N/A
 DRAWN: SFRN STAFF
 DESIGNED: N/A
 APPROVED: C.A.R.
 SCALE: NOTED



NORTHERN PALM BEACH COUNTY IMPROVEMENT DISTRICT

NORTHERN PALM BEACH IMPROVEMENT DISTRICT
 FACILITY MAP OF:
 UNIT OF DEVELOPMENT NO. 45
 SECTIONS 12, 13 AND 14,
 TOWNSHIP 41 SOUTH, RANGE 42 EAST,
 PALM BEACH COUNTY, FLORIDA

DATE: 06-15-06
 SHEET 2 OF 4
 EXHIBIT 45 (2)

Date/Time : Wed, 13 Nov 2013 10:30:11am
 Path/Name : C:\Projects\1213\13_Nov_2013\Current\Bicycle - BxColor - W\000000\CA0\Unit-45\Facilities Map\un45f01.dwg

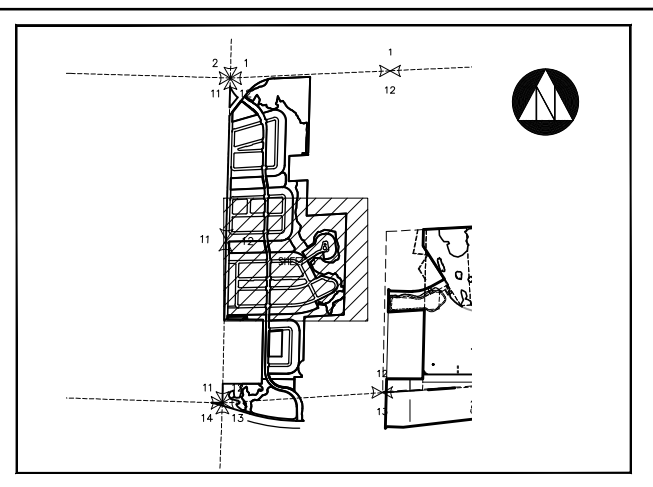
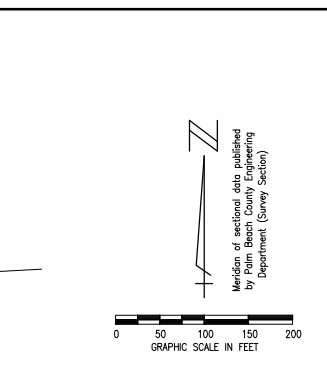
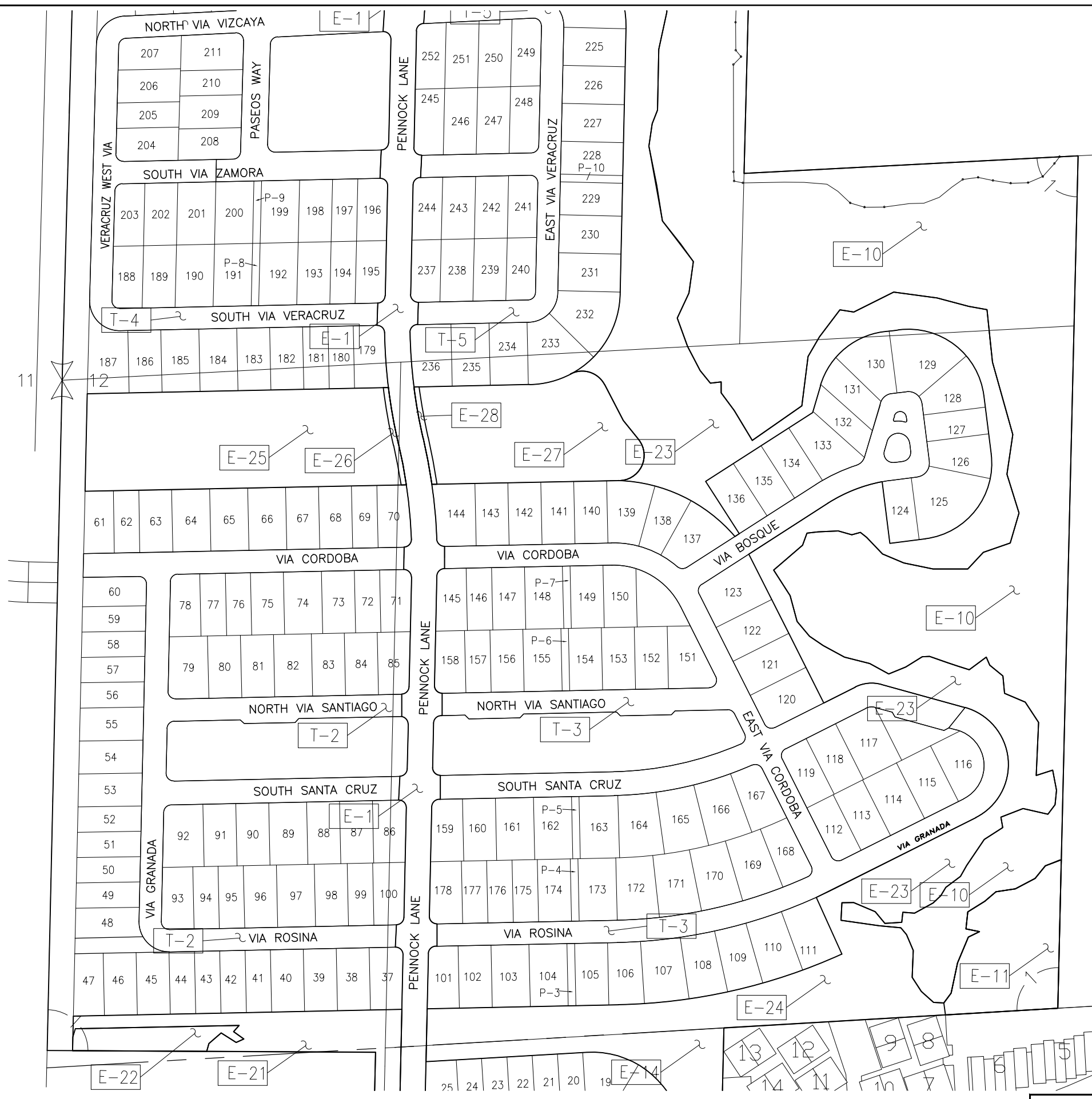

No.	TYPE	RECORDING DATA	INST. DATE	RECORDING DATE	EASEMENTS	REMARKS
E 1	IEE	PB 99/47-62	N/A	06/26/03	TRACT R-1	
E 10	IEE	PB 99/47-62	N/A	06/26/03	WETLAND 3	
E 11	PB	99/47-62	N/A	06/26/03	UPLAND 9	
E 14	PB	99/47-62	N/A	06/26/03	UPLAND 6	
E 21	PB	99/47-62	N/A	06/26/03	UPLAND 3	
E 22	PB	99/47-62	N/A	06/26/03	WETLAND 2	
E 23	PB	99/47-62	N/A	06/26/03	UPLAND 8	
E 24	PB	99/47-62	N/A	06/26/03	UPLAND 7	
E 25	PB	99/47-62	N/A	06/26/03	LAKE TRACT 4	
E 26	PB	99/47-62	N/A	06/26/03	OPEN SPACE 10	
E 27	PB	99/47-62	N/A	06/26/03	LAKE TRACT 5	
E 28	PB	99/47-62	N/A	06/26/03	OPEN SPACE 11	

No.	RECORDING DATA	INST. DATE	RECORDING DATE	OWNED TRACTS	REMARKS
T 2	PB 99/47-62	N/A	06/26/03	TRACT R-3	
T 3	PB 99/47-62	N/A	06/26/03	TRACT R-4	
T 4	PB 99/47-62	N/A	06/26/03	TRACT R-5	
T 5	PB 99/47-62	N/A	06/26/03	TRACT R-6	

No.	REMARKS

No.	PLAT BOOK/PAGES	TITLE
1	PB 99/47-62	PINES ON PENNOCK LANE, P.U.D. PLAT NO. 2 (PASEOS)

LOT NUMBER	BLANKET EASEMENT RELEASE RECORDING DATA

- LEGEND:**
- WME denotes Water Management Easement
 - WMME denotes Water Management Maintenance
 - IEE denotes Ingress-Egress Easement
 - GCAE denotes Golf Course Access Easement
 - WMAE denotes Water Management Access Easement
 - E denotes Utility Easement
 - DE denotes Drainage Easement
 - CE denotes Conservation Easement
 - PE denotes Preservation Easement
 - PT denotes Wetland Preservation Tract
 - WPA denotes Wetland Preservation Area WMT
 - MT denotes Water Management Tract
 - LOA denotes Land Owners Agreement
 - NPBOD denotes Northern Palm Beach County Improvement District
 - NGVD denotes National Geodetic Vertical Datum
 - IE denotes Invert Elevation (NGVD)
 - CMP denotes Corrugated Metal Pipe
 - RCP denotes Reinforced Concrete Pipe
 - denotes Recorded Plat Corner
 - denotes Palm Beach County Section Corner
 - denotes Palm Beach County Section Quarter Corner
 - denotes NPBCID Unit Boundary
 - denotes NPBCID Fee Simple Tract
 - denotes NPBCID Easements
 - denotes Palm Beach County Section Lines
 - IP-1 denotes Irrigation Pump
 - E-1 denotes District Easement
 - T-1 denotes District Owned Tract
 - F-1 denotes Flashboard Riser
 - W-1 denotes Weir
 - PS-1 denotes Pump Station
 - C-1 denotes Culvert
 - TE-1 denotes Telemetry Catwalk with Metritape
 - OS-2 denotes Operable Gate Structure
 - RW-1 denotes Recharge Well
 - MW-1 denotes Hazardous Material Monitoring Well
 - WQ-1 denotes Water Quality Sampling Station
 - SG-1 denotes Staff Gauge
 - RG-1 denotes Rainfall Gauge
 - denotes Flow direction

INFORMATION SHOWN HEREON DOES NOT CONSTITUTE, NOR DOES IT REPRESENT, A SURVEY OF THE SUBJECT PREMISES.

FIELD: N/A
 DRAWN: SFRN STAFF
 DESIGNED: N/A
 APPROVED: C.A.R.
 SCALE: NOTED

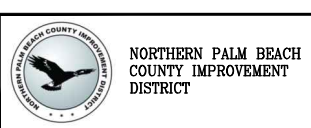

NORTHERN PALM BEACH IMPROVEMENT DISTRICT
 FACILITY MAP OF:
 UNIT OF DEVELOPEMENT NO. 45
 SECTIONS 12, 13 AND 14,
 TOWNSHIP 41 SOUTH, RANGE 42 EAST,
 PALM BEACH COUNTY, FLORIDA

DATE: 06-15-06
 SHEET 3 OF 4
 EXHIBIT 45(3)

Date: Wed, 13 Nov 2013 3:01pm
 Path: C:\Projects\1311\1311_WF050000\CAD\Unit-45\Facilities_Map\un45r01.dwg
 Current Plotstyle: BkColor
 Plot Name: C:\Projects\1311\1311_WF050000\CAD\Unit-45\Facilities_Map\un45r01.dwg

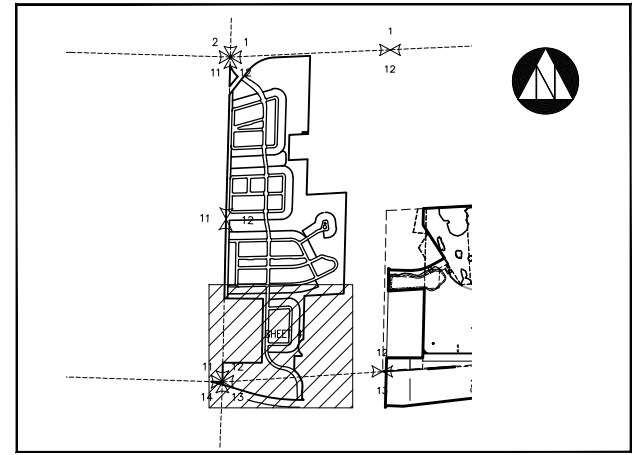
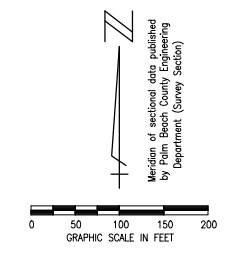
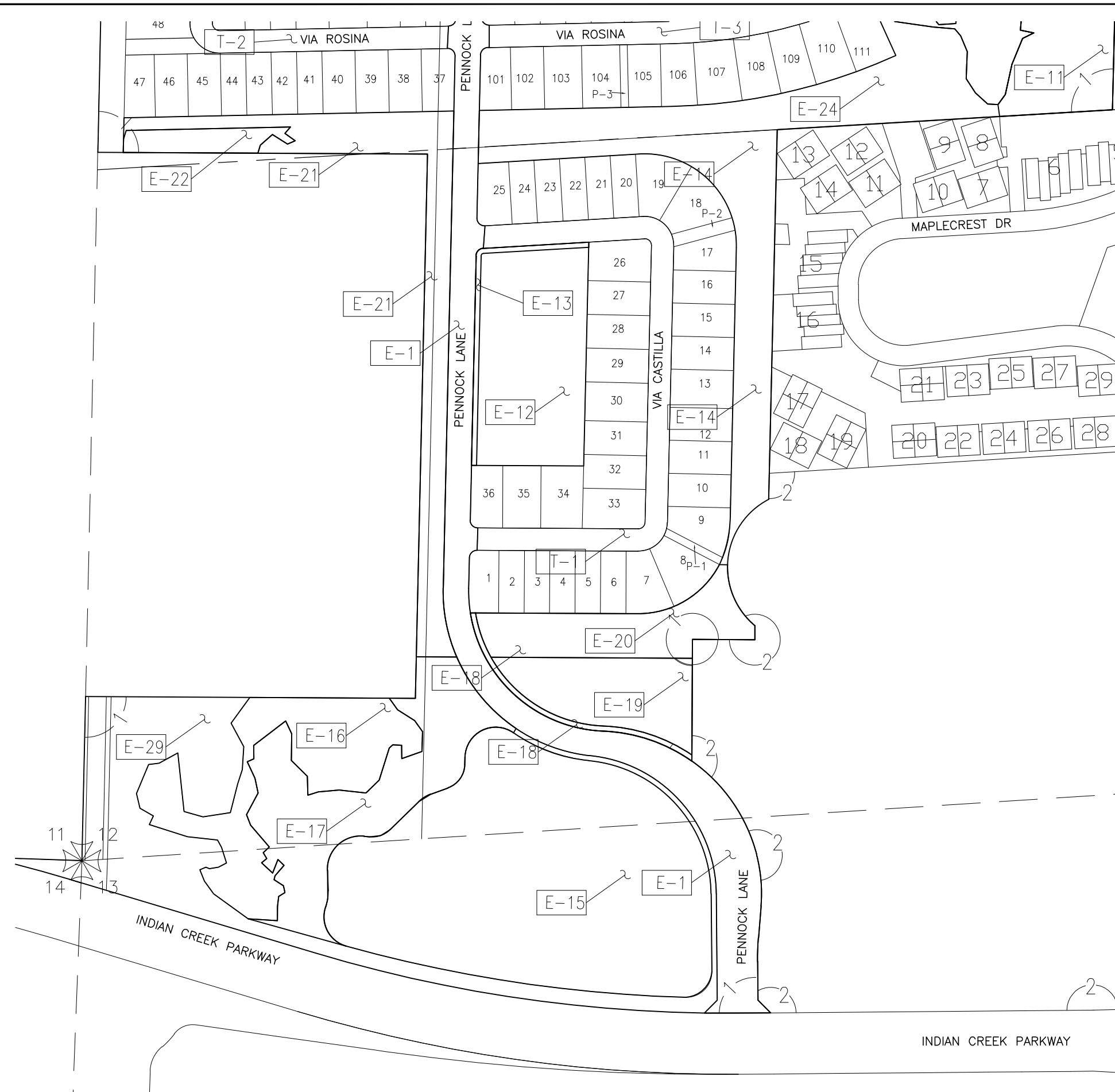

No.	TYPE	RECORDING DATA	INST. DATE	RECORDING DATE	REMARKS
E-1	IEE	PB 99/47-62	N/A	06/26/03	TRACT R-1
E-11	PB	99/47-62	N/A	06/26/03	UPLAND 9
E-12	PB	99/47-62	N/A	06/26/03	LAKE TRACT 3
E-13	PB	99/47-62	N/A	06/26/03	OPEN SPACE 22
E-14	PB	99/47-62	N/A	06/26/03	UPLAND 6
E-15	PB	99/47-62	N/A	06/26/03	LAKE TRACT 2
E-16	PB	99/47-62	N/A	06/26/03	WETLAND 1
E-17	PB	99/47-62	N/A	06/26/03	UPLAND 2
E-18	PB	99/47-62	N/A	06/26/03	OPEN SPACE 19
E-19	PB	99/47-62	N/A	06/26/03	UPLAND 4
E-20	PB	99/47-62	N/A	06/26/03	UPLAND 5
E-21	PB	99/47-62	N/A	06/26/03	UPLAND 3
E-22	PB	99/47-62	N/A	06/26/03	WETLAND 2
E-23	PB	99/47-62	N/A	06/26/03	UPLAND 8
E-24	PB	99/47-62	N/A	06/26/03	UPLAND 7
E-29	PB	99/47-62	N/A	06/26/03	UPLAND 1

No.	RECORDING DATA	INST. DATE	RECORDING DATE	OWNED TRACTS	REMARKS
T-1	PB 99/47-62	N/A	06/26/03	TRACT R-2	
T-2	PB 99/47-62	N/A	06/26/03	TRACT R-3	
T-3	PB 99/47-62	N/A	06/26/03	TRACT R-4	

No.	REMARKS

No.	PLAT BOOK/PAGES	TITLE
1	PB 99/47-62	PIPES ON PENNOCK LANE, P.U.D. PLAT NO. 2 (PASEOS)

LOT NUMBER	BLANKET EASEMENT RELEASE RECORDING DATA

LEGEND:

- WME denotes Water Management Easement
- WMME denotes Water Management Maintenance
- IEE denotes Ingress-Egress Easement
- GCAE denotes Golf Course Access Easement
- WMAE denotes Water Management Access Easement
- E denotes Utility Easement
- DE denotes Drainage Easement
- CE denotes Conservation Easement
- PE denotes Preservation Easement
- PT denotes Wetland Preservation Tract
- WPA denotes Wetland Preservation Area WMT
- MT denotes Water Management Tract
- LOA denotes Land Owners Agreement
- NPBCID denotes Northern Palm Beach County Improvement District
- NGVD denotes National Geodetic Vertical Datum
- IE denotes Invert Elevation (NGVD)
- CMP denotes Corrugated Metal Pipe
- RCP denotes Reinforced Concrete Pipe
- 22 23 27 26 denotes Recorded Plat Corner
- 22 23 27 26 denotes Palm Beach County Section Corner
- 22 27 27 26 denotes Palm Beach County Section Quarter Corner
- denotes NPBCID Unit Boundary
- - - denotes NPBCID Fee Simple Tract
- - - denotes NPBCID Easements
- - - denotes Palm Beach County Section Lines
- IP-1 denotes Irrigation Pump
- E-1 denotes District Easement
- T-1 denotes District Owned Tract
- F-1 denotes Flashboard Riser
- W-1 denotes Weir
- PS-1 denotes Pump Station
- C-1 denotes Culvert
- TE-1 denotes Telemetry Catwalk with Metritape
- OS-2 denotes Operable Gate Structure
- RW-3 denotes Recharge Well
- MW-3 denotes Hazardous Material Monitoring Well
- WQ-3 denotes Water Quality Sampling Station
- SG-3 denotes Staff Gauge
- RG-3 denotes Rainfall Gauge
- ~ denotes Flow direction

No.	DATE	BY	REVISION
5	11-26-13	JAF	REVISE BORDER
4	02-29-06	MCB	NPBCID FACILITIES UPDATE
3	02-17-05	JCD	NPBCID FACILITIES UPDATE
1	MAR 04	JD	ADDED EASEMENTS AND TRACTS FOR PLAT 2

INFORMATION SHOWN HEREON DOES NOT CONSTITUTE, NOR DOES IT REPRESENT, A SURVEY OF THE SUBJECT PREMISES.