

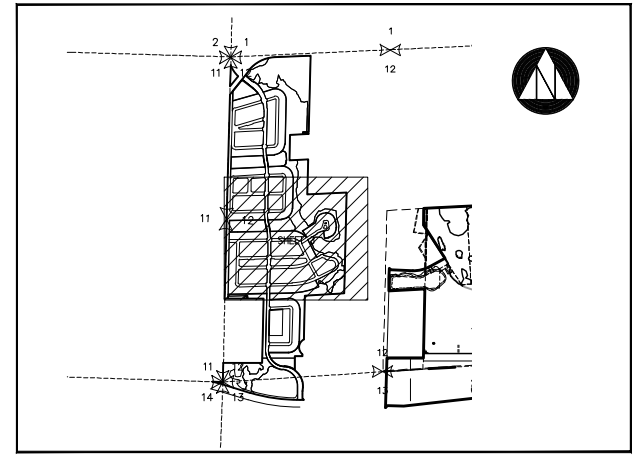

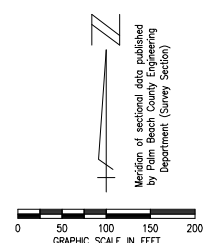

File Name : Mon\_07\_Dec\_2020 - 5:57am  
 Path Name : c:\Users\jlitigraod\Documents\Jannies Files\WORK DWG\5\WP055000 NPBCID UNIT 45\Facilities Map\un45fmc01.dwg

INFORMATION SHOWN HEREON DOES NOT CONSTITUTE, NOR DOES IT REPRESENT, A SURVEY OF THE SUBJECT PREMISES.



No.	TYPE	RECORDING DATA	INST. DATE	RECORDING DATE	NPBCID EASEMENTS	REMARKS
E 1	IEE	PB 99/47-62	N/A	06/26/03	TRACT R-1	
E 10	IEE	PB 99/47-62	N/A	06/26/03	WETLAND 3	
E 11	PB	99/47-62	N/A	06/26/03	UPLAND 9	
E 14	PB	99/47-62	N/A	06/26/03	UPLAND 6	
E 21	PB	99/47-62	N/A	06/26/03	UPLAND 3	
E 22	PB	99/47-62	N/A	06/26/03	WETLAND 2	
E 23	PB	99/47-62	N/A	06/26/03	UPLAND 8	
E 24	PB	99/47-62	N/A	06/26/03	UPLAND 7	
E 25	PB	99/47-62	N/A	06/26/03	LAKE TRACT 4	
E 26	PB	99/47-62	N/A	06/26/03	OPEN SPACE 10	
E 27	PB	99/47-62	N/A	06/26/03	LAKE TRACT 5	
E 28	PB	99/47-62	N/A	06/26/03	OPEN SPACE 11	

No.	RECORDING DATA	INST. DATE	RECORDING DATE	NPBCID OWNED TRACTS	REMARKS
T 2	PB 99/47-62	N/A	06/26/03	TRACT R-3	
T 3	PB 99/47-62	N/A	06/26/03	TRACT R-4	
T 4	PB 99/47-62	N/A	06/26/03	TRACT R-5	
T 5	PB 99/47-62	N/A	06/26/03	TRACT R-6	

No.	NPBCID FACILITIES	REMARKS

No.	PLAT BOOK/PAGES	RECORDED PLATS	TITLE
1	PB 99/47-62		PINES ON PENNOCK LANE P.L.D. PLAT NO. 2 (PASEOS)

LOT NUMBER	BLANKET EASEMENT RELEASE RECORDING DATA

- LEGEND:**
- WME denotes Water Management Easement
  - WMME denotes Water Management Maintenance
  - IEE denotes Ingress-Egress Easement
  - GCAE denotes Golf Course Access Easement
  - WMAE denotes Water Management Access Easement
  - E denotes Utility Easement
  - DE denotes Drainage Easement
  - CE denotes Conservation Easement
  - PE denotes Preservation Easement
  - PT denotes Wetland Preservation Tract
  - WPA denotes Wetland Preservation Area WMT
  - MT denotes Water Management Tract
  - LOA denotes Land Owners Agreement
  - NPBCID denotes Northern Palm Beach County Improvement District
  - NGVD denotes National Geodetic Vertical Datum
  - IE denotes Invert Elevation (NGVD)
  - CMP denotes Corrugated Metal Pipe
  - RCP denotes Reinforced Concrete Pipe
  - denotes Recorded Plat Corner
  - denotes Palm Beach County Section Corner
  - denotes Palm Beach County Section Quarter Corner
  - denotes NPBCID Unit Boundary
  - denotes NPBCID Fee Simple Tract
  - denotes NPBCID Easements
  - denotes Palm Beach County Section Lines
  - IP-1 denotes Irrigation Pump
  - E-1 denotes District Easement
  - T-1 denotes District Owned Tract
  - F-1 denotes Flashboard Riser
  - W-1 denotes Weir
  - PS-1 denotes Pump Station
  - C-1 denotes Culvert
  - TE-1 denotes Telemetry Catwalk with Metritape
  - OS-2 denotes Operable Gate Structure
  - RW-1 denotes Recharge Well
  - MW-1 denotes Hazardous Material Monitoring Well
  - WQ-1 denotes Water Quality Sampling Station
  - SG-1 denotes Staff Gauge
  - RG-1 denotes Rainfall Gauge
  - denotes Flow direction

FIELD: N/A  
 DRAWN: SFRN STAFF  
 DESIGNED: N/A  
 APPROVED: C.A.R.  
 SCALE: NOTED

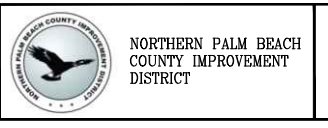

**NORTHERN PALM BEACH COUNTY IMPROVEMENT DISTRICT**  
 FACILITIES MAP UNIT OF DEVELOPMENT NO. 45  
 IN SECTIONS SECTIONS 12, 13 AND 14,  
 T. 41 S., R. 42 E.,  
 PALM BEACH COUNTY, FLORIDA

DATE: 06-15-06  
 SHEET 3 OF 4  
 EXHIBIT 45(3)



